



Politechnika  
Wroclawska

# Adhesive bonding in materials engineering

Łukasz Sadowski  
lukasz.sadowski@pwr.edu.pl

Wroclaw University of Science and Technology  
Faculty of Civil Engineering  
Department of Materials Engineering and Construction Processes



Politechnika  
Wroclawska

# Multi-scale adhesion phenomena

# Introduction & background

## Cement composite

should be understood as a material made up of a minimum of two components: a cement matrix and aggregate, in such a way that it should have properties superior to the components taken separately.

Level of adhesion in layered systems from cement composites using a multi-scale approach

## Level of adhesion

the value of the pull-off adhesion  $f_b$  (in MPa) between the overlay and the substrate

### Overlay

with constant or variable thickness (usually made of cement mortar)

### Substrate

(usually made of concrete)

### Layered system

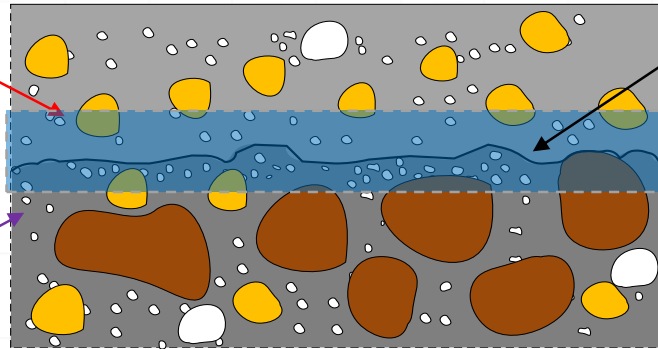

Interlayer bond

Interphase zone

### Scale I (macro)

1m

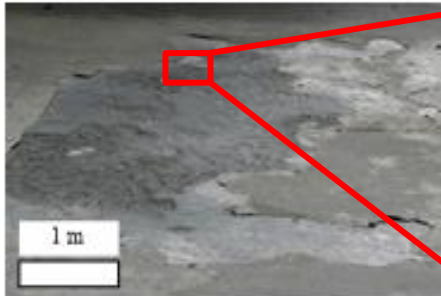

### Scale II (meso)

$10^{-3}m$

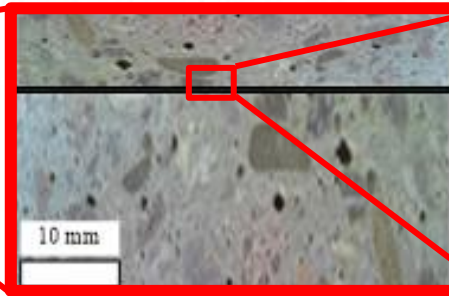

### Scale III (micro)

$10^{-6}m$

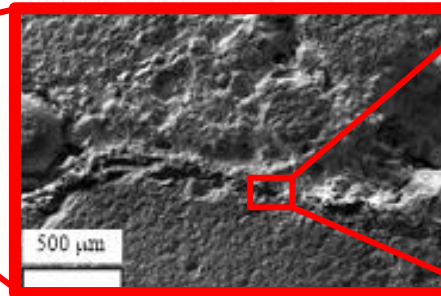

### Scale IV (nano)

$10^{-9}m$

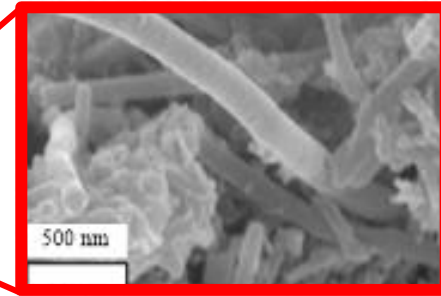

# Literature review

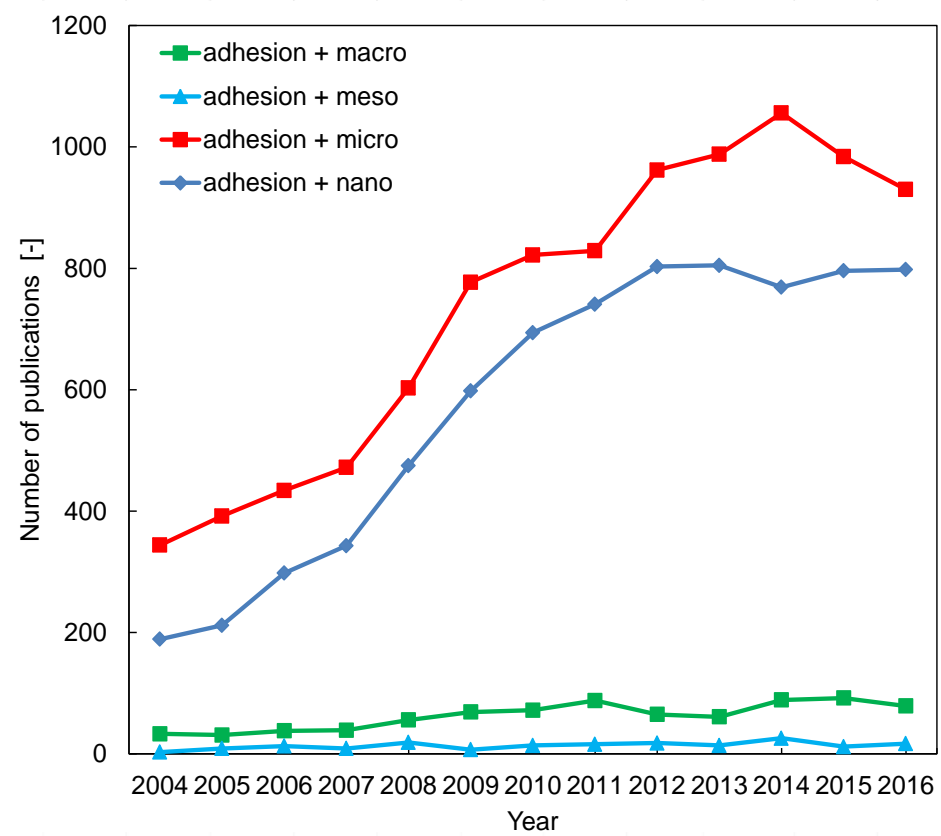
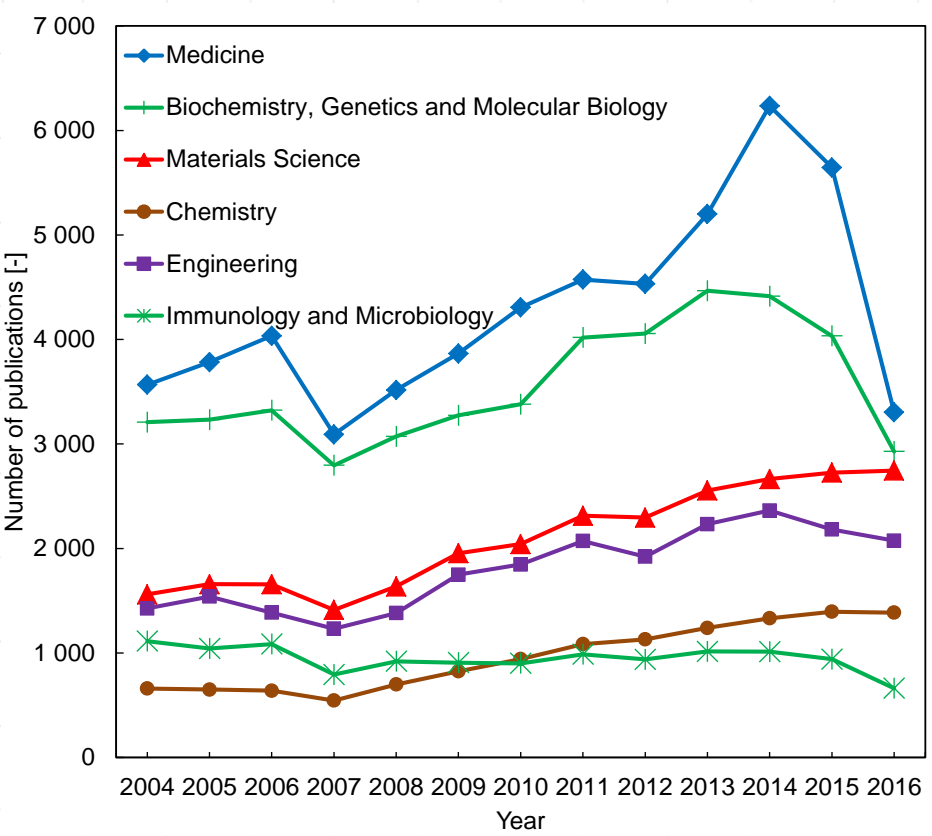

Analysis of a number of publications regarding adhesion and divided into individual scientific disciplines (and different levels of observation (results for "adhesion" in the "abstract, title or keyword" in the Scopus database - state for 23.12.2017)

# Scales of the identification

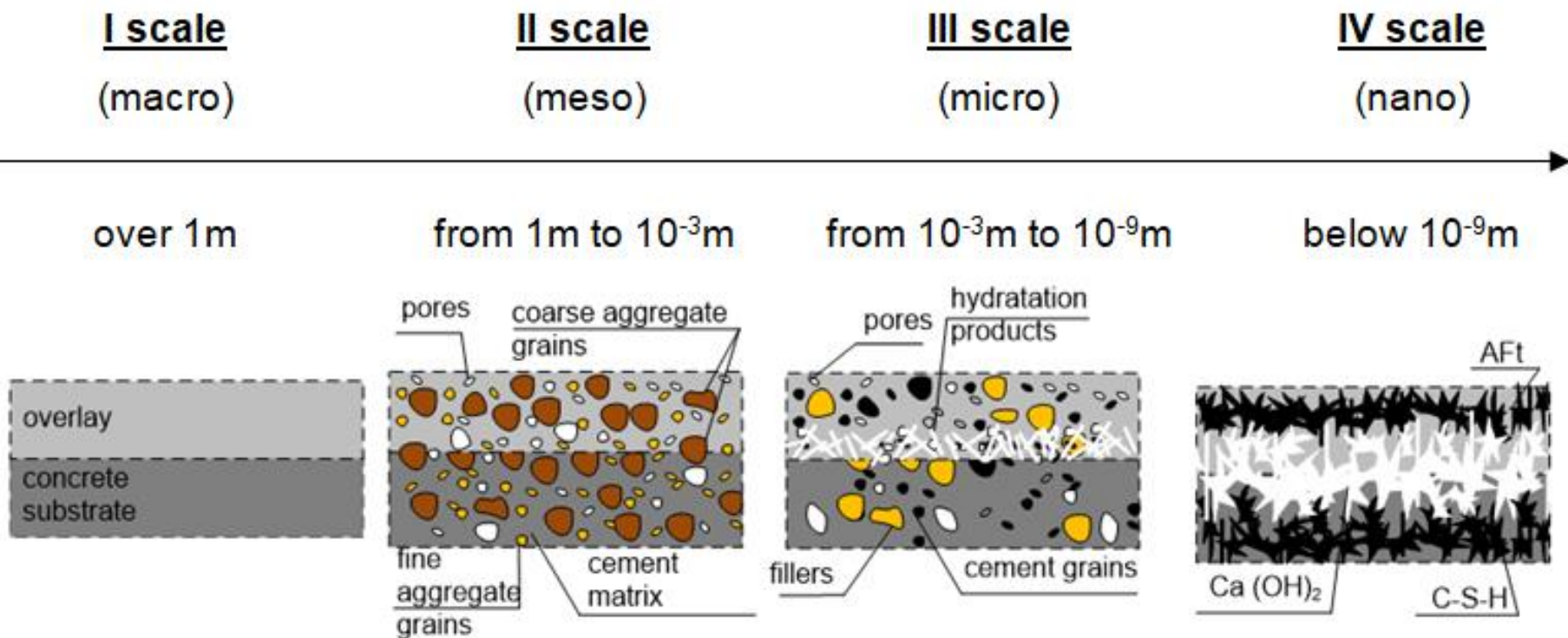

Four scales of the identification (observation) of the level of adhesion of layered systems made of cement composites

# Scales of the identification

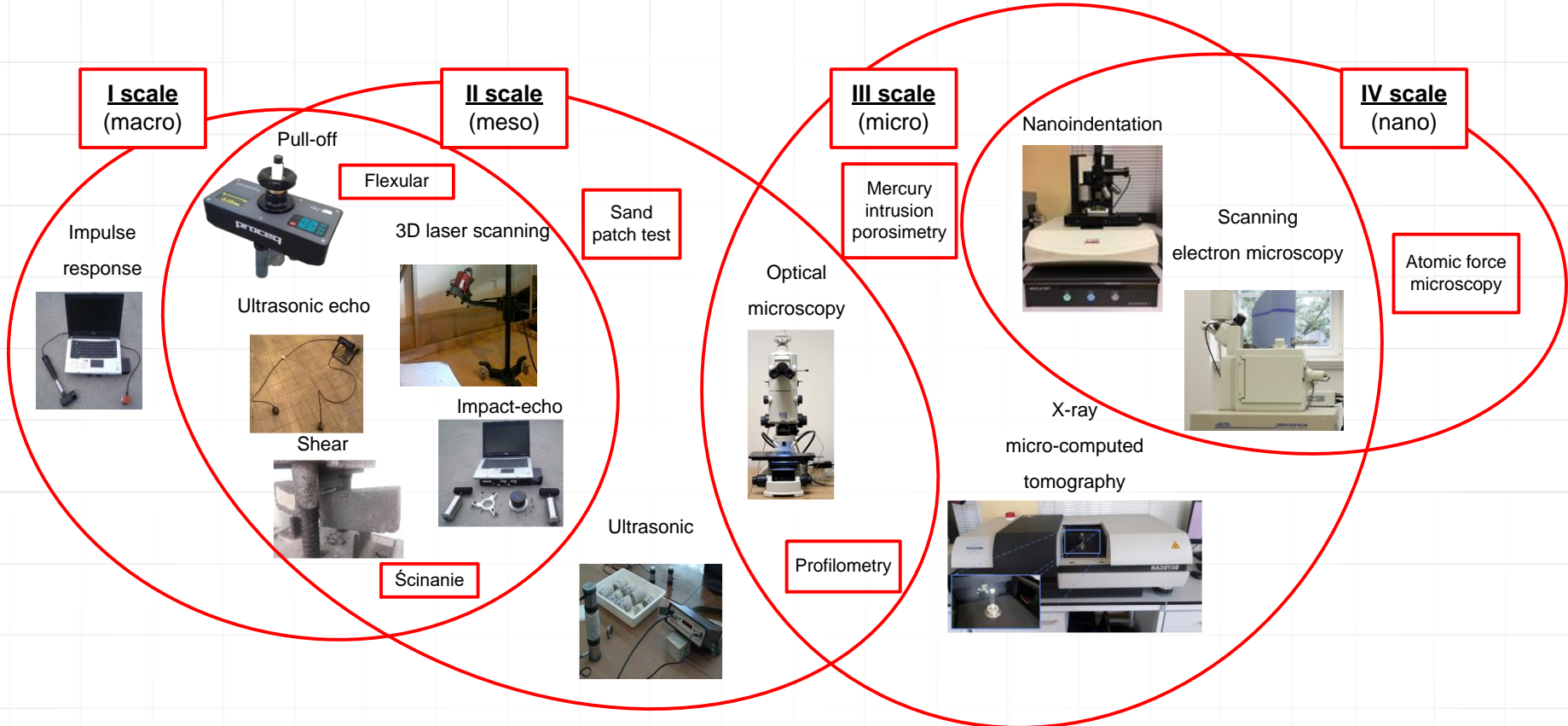

The usefulness of available test methods depending on the scale of observation of the level of adhesion of layered systems made of cement composites

# Scales of the identification

The usefulness of available test methods depending on the scale of observation

Name of the test method	Basic descriptors	Usefulness on the scale of observation
<b>Pull-off</b>	$f_b$ - pull-off adhesion	I, II
<b>3D laser scanning</b>	$S_{ku}$ - kurtosis, $S_{tr}$ - texture aspect ratio, $S_a$ - arithmetical mean height, $S_{dr}$ - developed interfacial area ratio, $S_q$ - root mean square height, $S_{sk}$ - skewness, $V_{mp}$ - peak material volume.	I, II
<b>Impulse response</b>	$K_d$ - dynamic stiffness, $M_p/N$ - mobility slope, $N_{av}$ - average mobility, $v$ - voids index.	I, II
<b>Impact-echo</b>	$A$ - amplitude of transmitted ultrasonic wave, $f_T$ - frequency of reflection of the ultrasonic wave from the bottom.	I, II
<b>Optical microscopy</b>	$A_A$ - the contribution of the exposed aggregate on the substrate	II, III
<b>X-ray micro-computed tomography</b>	$\mu$ - materials attenuation coefficient	III
<b>Scanning electron microscopy (SEM) with the EDS</b>	$w_i$ - percentage share of the atoms of elements and oxides	III, IV

# Proposal of the methodology

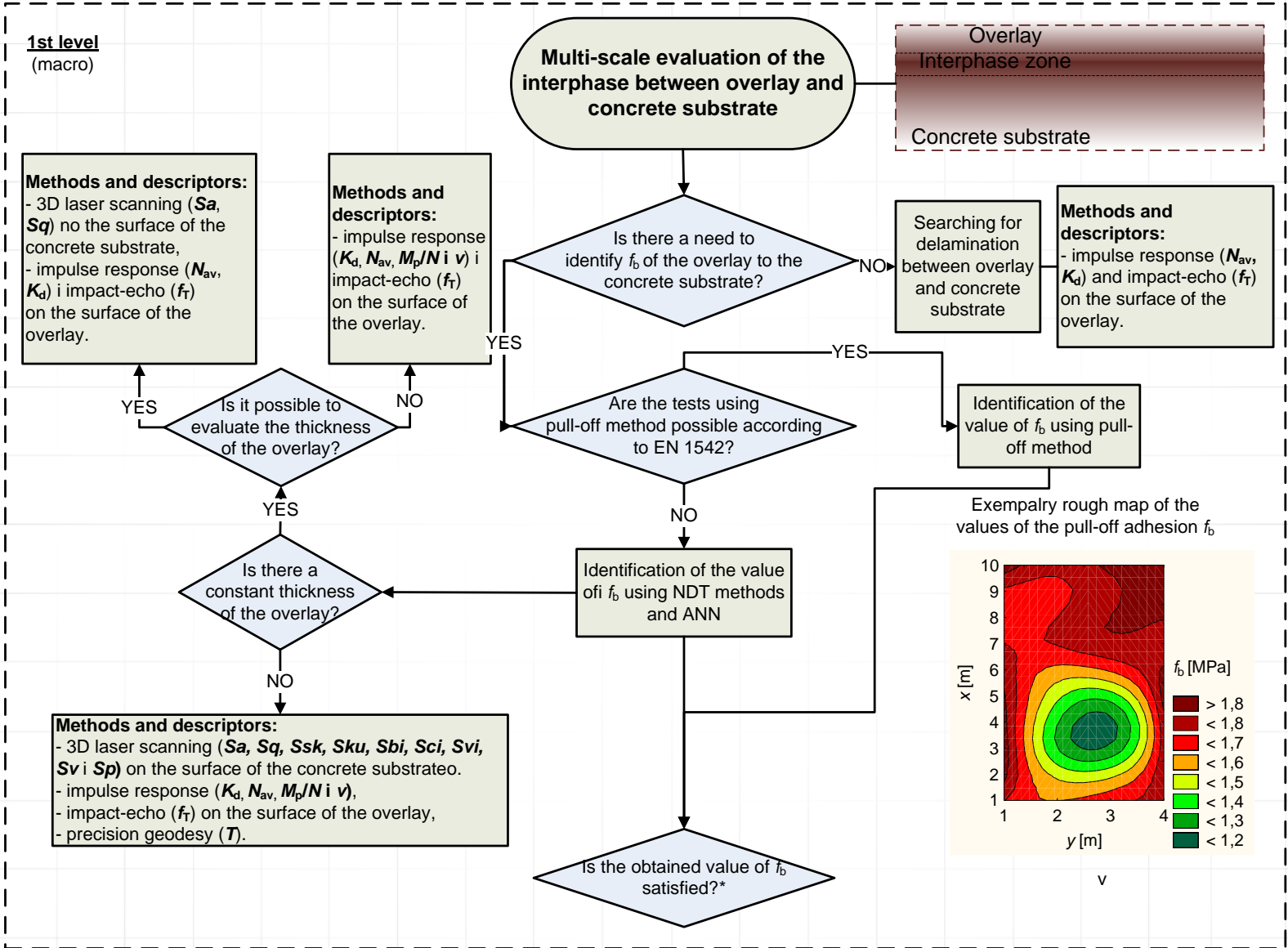



# Proposal of the methodology

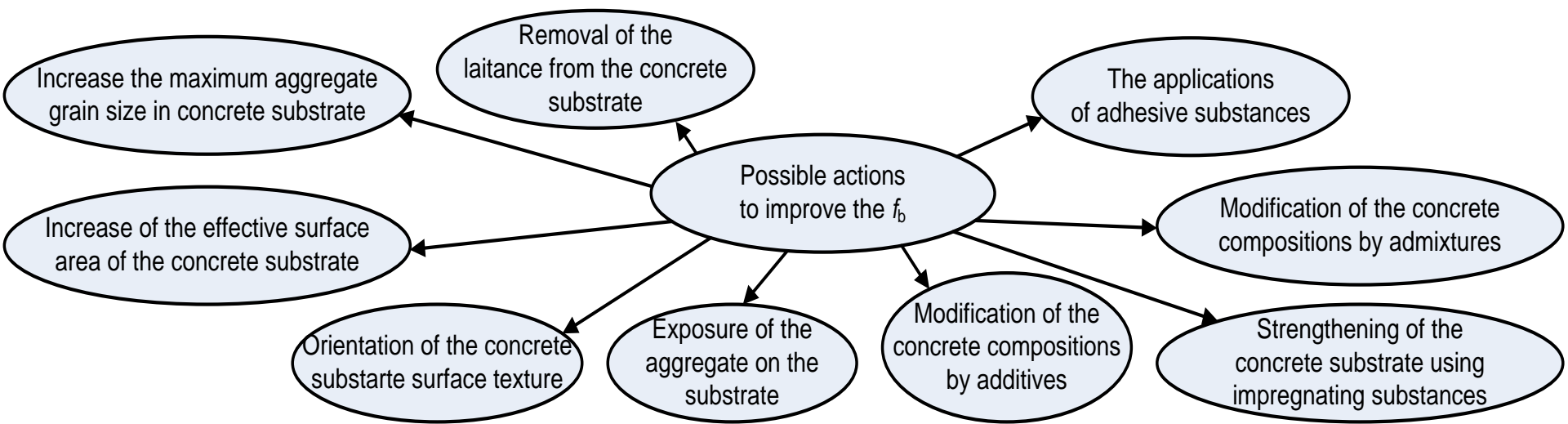

# Proposal of the methodology

## 2nd level

(meso)

**Methods and descriptors:**  
 - 3D laser scanning (*Str, Sdr, Vmp*),  
 - optical microscopy (*A<sub>A</sub>*).

Optical view of the surface of the concrete substrate



3D isometric view of the surface of the concrete substrate

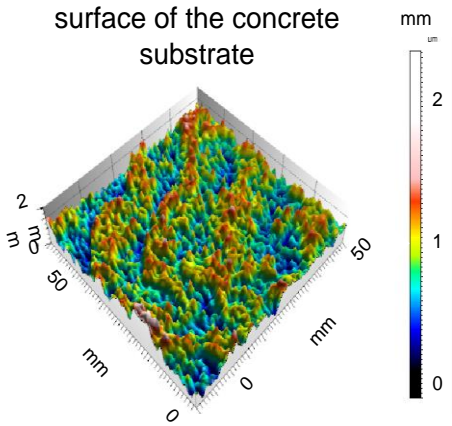

## 3rd level

(micro)

**Methods and descriptors**  
 - micro-CT ( $\mu$ ),  
 - nanoindentation (*M, H*).

Structure of pores in concrete within the interphase between overlay and substrate

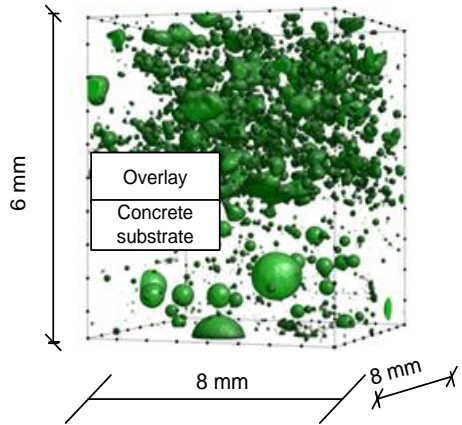

## 4th level

(nano)

**Methods and descriptors**  
 - SEM ( $w_i$ )

Chemical composition of the concrete within the interphase between overlay and substrate

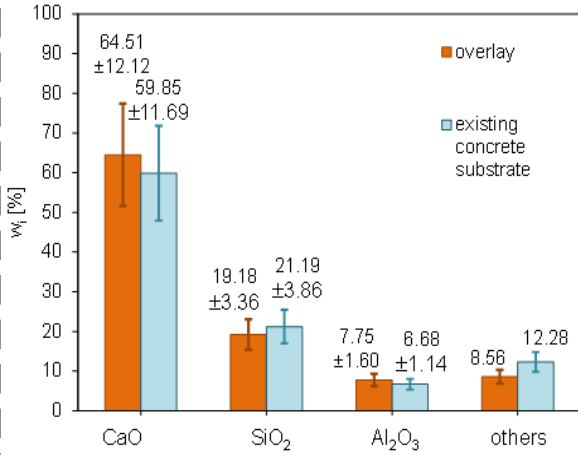

## Related papers

1. **Sadowski Ł.**, Żak A., Hoła J., 2018, Multi-sensor evaluation of the concrete within the interlayer bond with regards to pull-off adhesion, *Archives of Civil and Mechanical Engineering*, vol. 18 (2), s. 573-582.
2. **Sadowski Ł.**, Hoła J., Czarnecki S., Wang D., 2018, Pull-off adhesion prediction of variable thick overlay to the substrate, *Automation in Construction*, vol. 85, s. 10-23.
3. **Sadowski Ł.**, 2018, Methodology of the assessment of the interlayer bond in concrete composites using NDT methods. *Journal of Adhesion Science and Technology*, vol. 32 (2), s. 139-157.
4. **Sadowski Ł.**, Stefaniuk D., 2018, The effect of surface treatment on the microstructure of the skin of concrete. *Applied Surface Science*, vol. 427PB, s. 934-941.
5. **Sadowski Ł.**, 2017, Multi-scale evaluation of the interphase zone between the overlay and concrete substrate: methods and descriptors, *Applied Sciences*, vol. 7 (9), art. 893.
6. **Sadowski Ł.**, Stefaniuk D., Hoła J., 2017, The effect of the porosity within the interfacial zone between layers on pull-off adhesion, *Construction and Building Materials*, vol. 152, s. 887-897.
8. **Sadowski Ł.**, Stefaniuk D., 2017, Microstructural Evolution within the Interphase between Hardening Overlay and Existing Concrete Substrates, *Applied Sciences*, vol. 7 (2), art. 123.
9. **Sadowski Ł.**, Hoła J., Czarnecki S., 2016, Non-destructive neural identification of the bond between concrete layers in existing elements, *Construction and Building Materials*, vol. 127, s. 49-58.
10. **Sadowski Ł.**, Mathia T. G., 2016, Multi-scale metrology of concrete surface morphology: fundamentals and specificity, *Construction and Building Materials*, vol. 113, s. 613-621.



Politechnika  
Wroclawska

# Epoxy adhesives

# Plan of presentation

## MODIFICATION OF THE EPOXY RESIN COATINGS USING WASTE GLASS POWDER

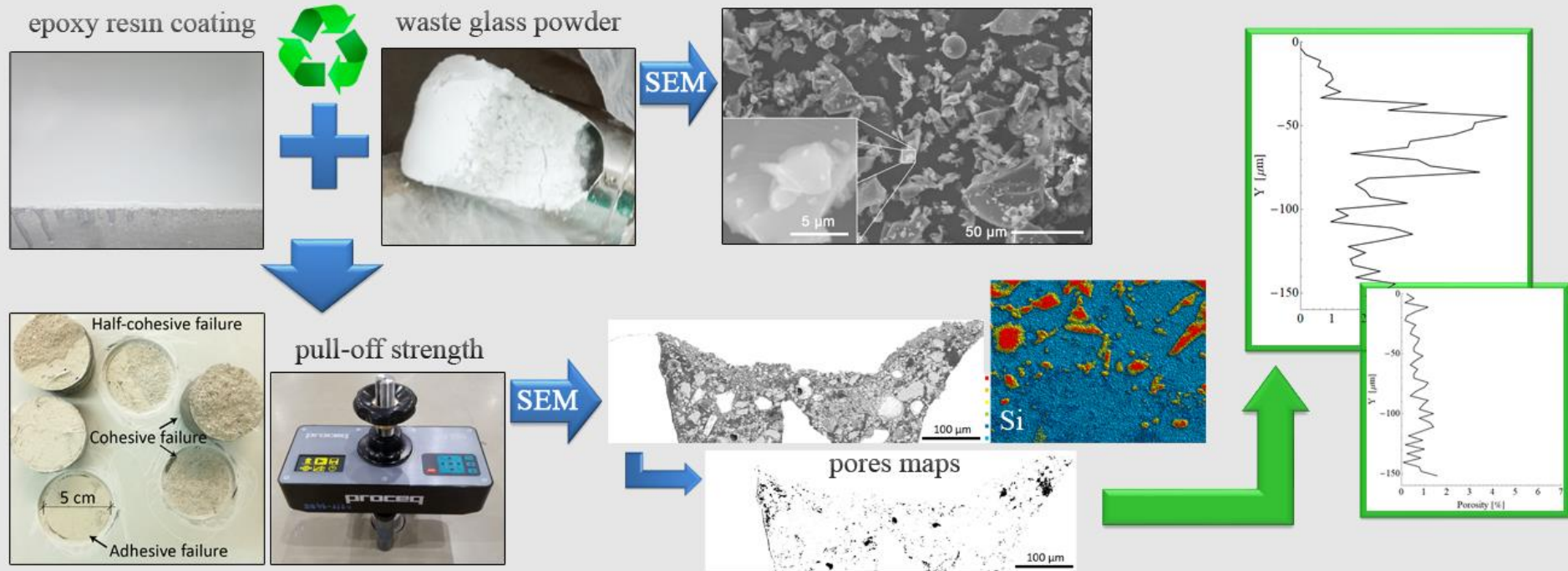



# Epoxy resin coatings

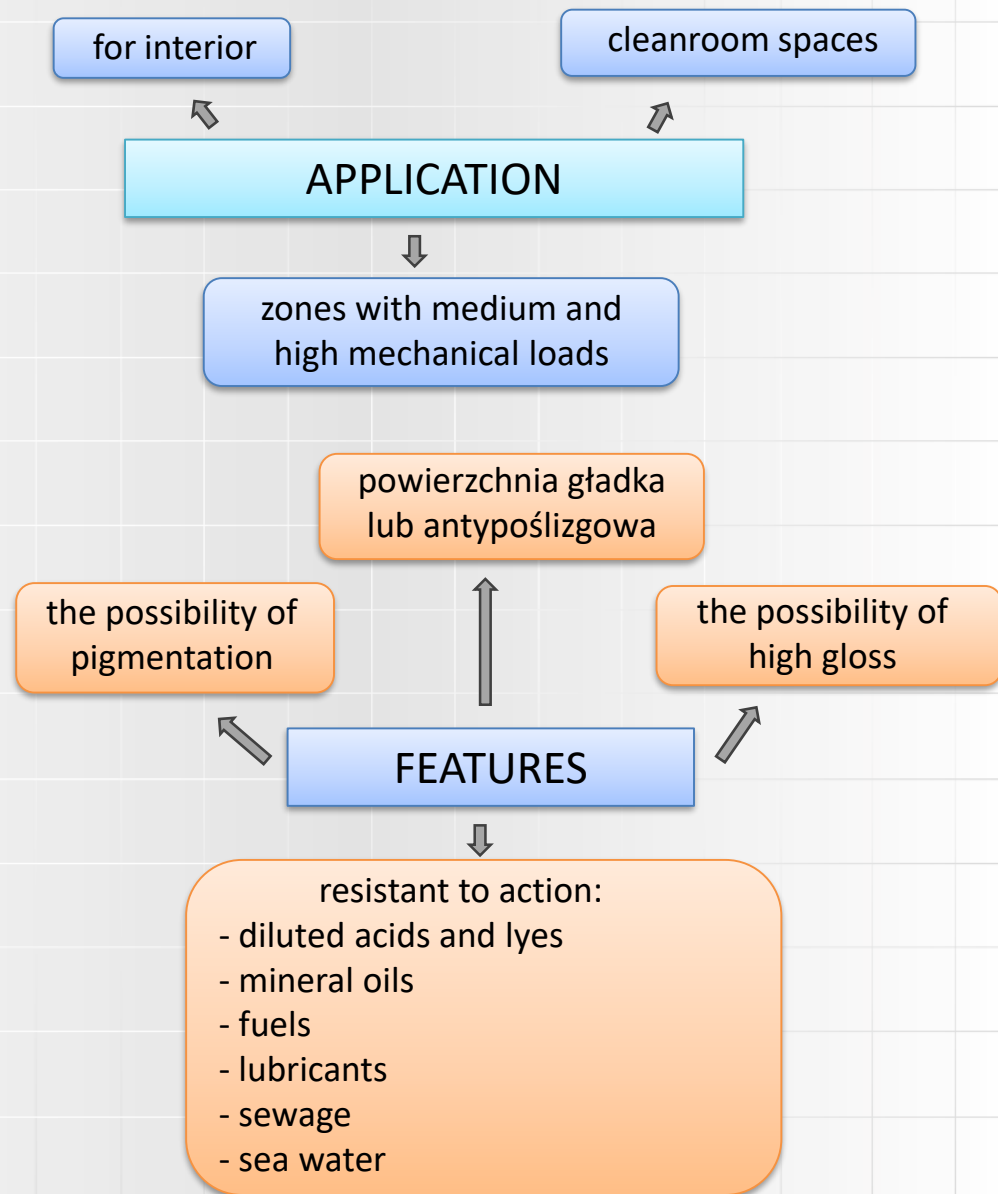





# Required preparation of cement substrate



Sanding the floor surface



Vacuuming



Application of tacking layer



Application of resin coating



# Research goals

1. Obtaining the required strength when tearing the epoxy resin coating from the cement substrate without first mechanically preparing the substrate and applying the adhesives.
2. Determining the optimal ratio between the base material and the additive.





# Components of the coating

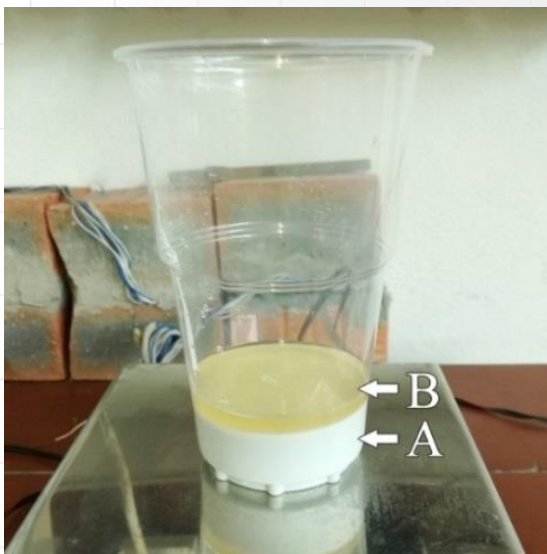

**StoPox BB OS, Sto-ispo Sp. z o.o.:**

- **component A** an epoxy resin based on bisphenol A, preferably with a molecular weight  $<700$  of 64.5-74.1% by weight,
- **component B** which acts as a hardener based on aliphatic polyamines in an amount of 16.1-18.5% by weight.

- **component C** contains a filler in the form of glass powder, preferably at least 90% of a plurality of grains with a diameter of less than 63 microns, preferably containing in its composition massively about 71%  $\text{SiO}_2$ , 1%  $\text{Al}_2\text{O}_3$ , 9%  $\text{CaO}$ , 4%  $\text{MgO}$ , 14%  $\text{Na}_2\text{O} + \text{K}_2\text{O}$  and a maximum of 0.1%  $\text{TiO}_2$  in an amount of 7.4 to 19.4% by weight.

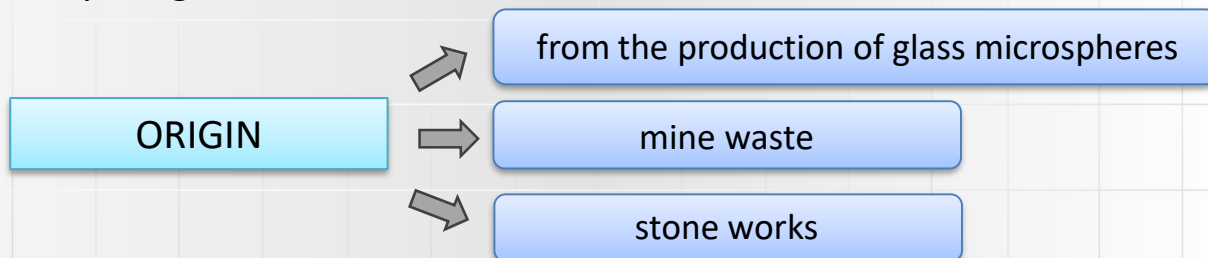

# component C - waste glass powder

X-ray diffraction spectrum with graph  
of chemical composition of glass  
powder

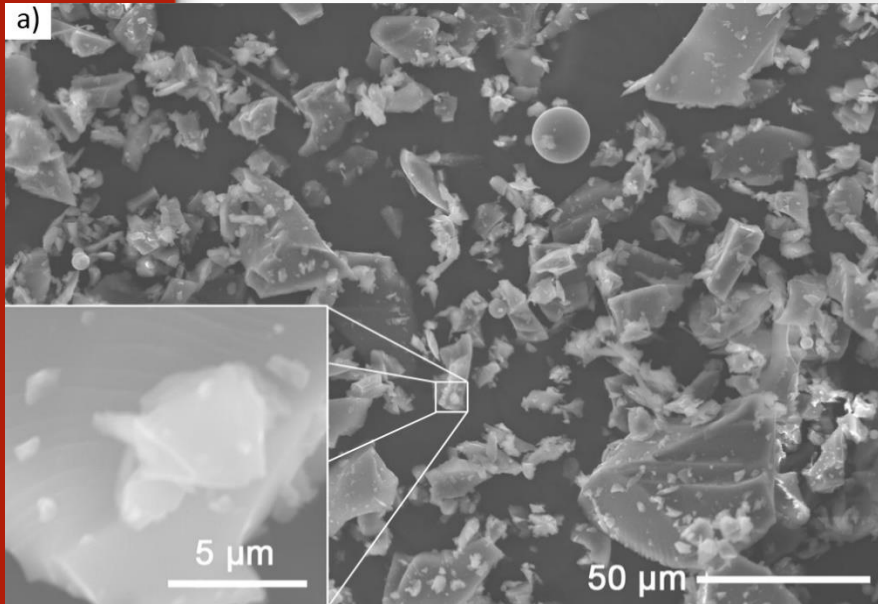
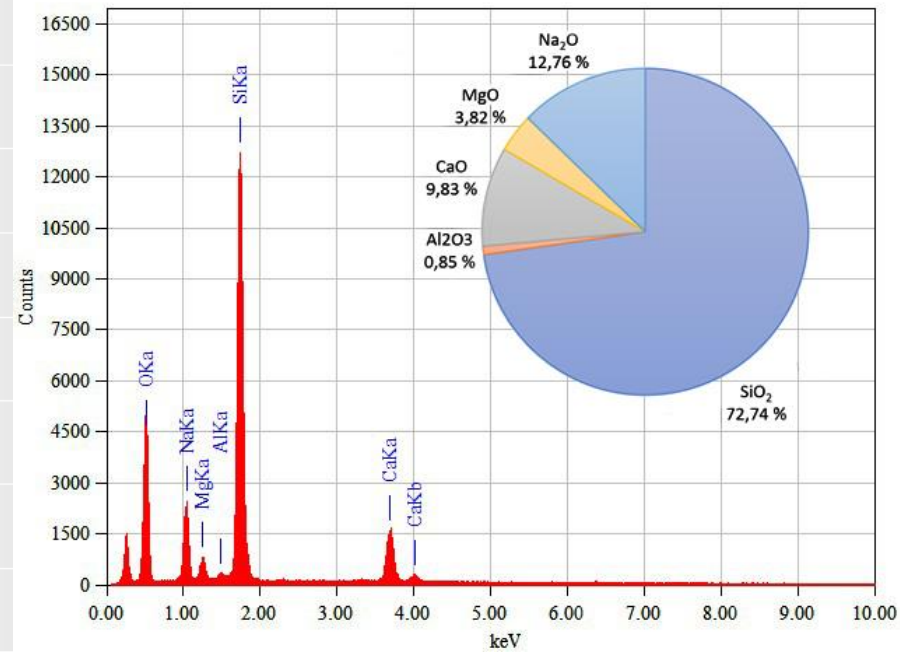

Waste glass powder- image made with scanning  
electron microscope (SEM)

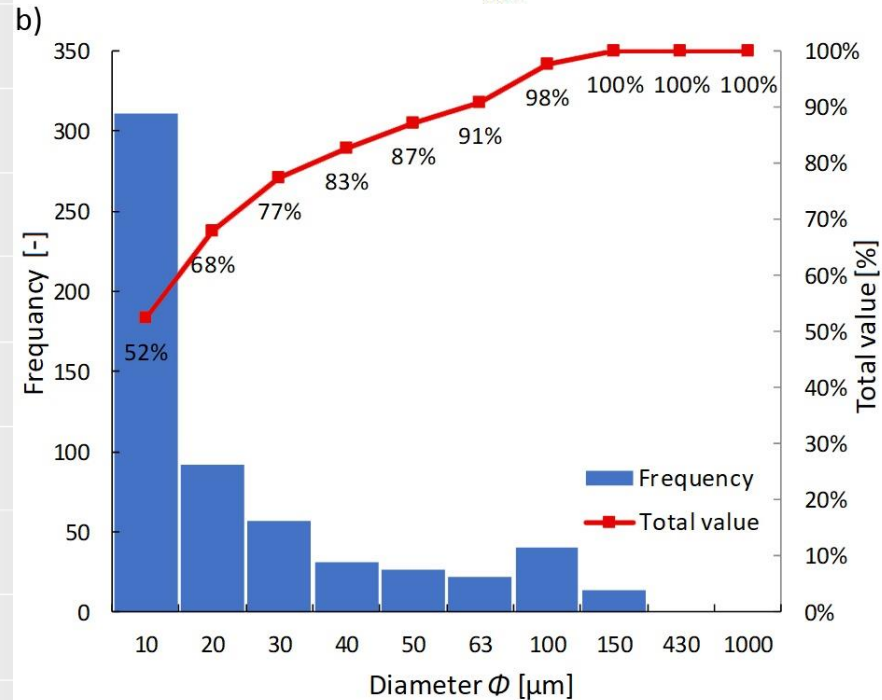

The distribution of the particle diameter



# Mixing proportions

Series	Square	Component (%)		
		A	B	C glass powder
GS and RS - ground surface and raw surface	GS-R/RS-R	80,0	20,0	0,0
	GS1/RS1	74,1	18,5	7,4
	GS2/RS2	69,0	17,2	13,8
	GS3/RS3	64,5	16,1	19,4
	GS4/RS4	60,6	15,2	24,2
	GS5/RS5	57,1	14,3	28,6
	GS6/RS6	54,1	13,5	32,4
	GS7/RS7	51,3	12,8	35,9
	GS8/RS8	48,8	12,2	39,0
	GS9/RS9	46,5	11,6	41,9
GS10/RS10	44,4	11,1	44,4	



# View of the substrate with division into squares

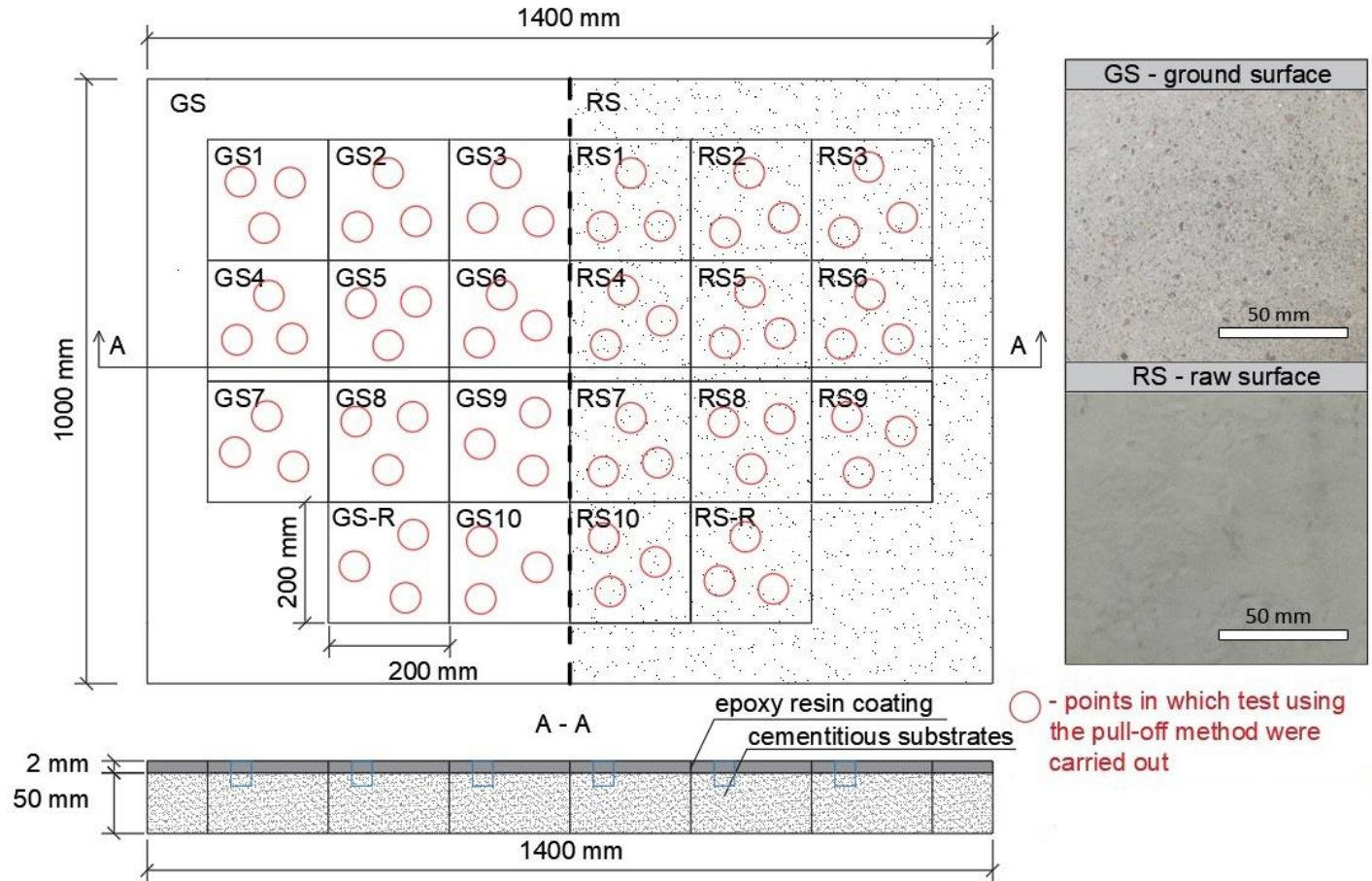

The stages of application of epoxy resin coating





# View of the test bench for pull-off test

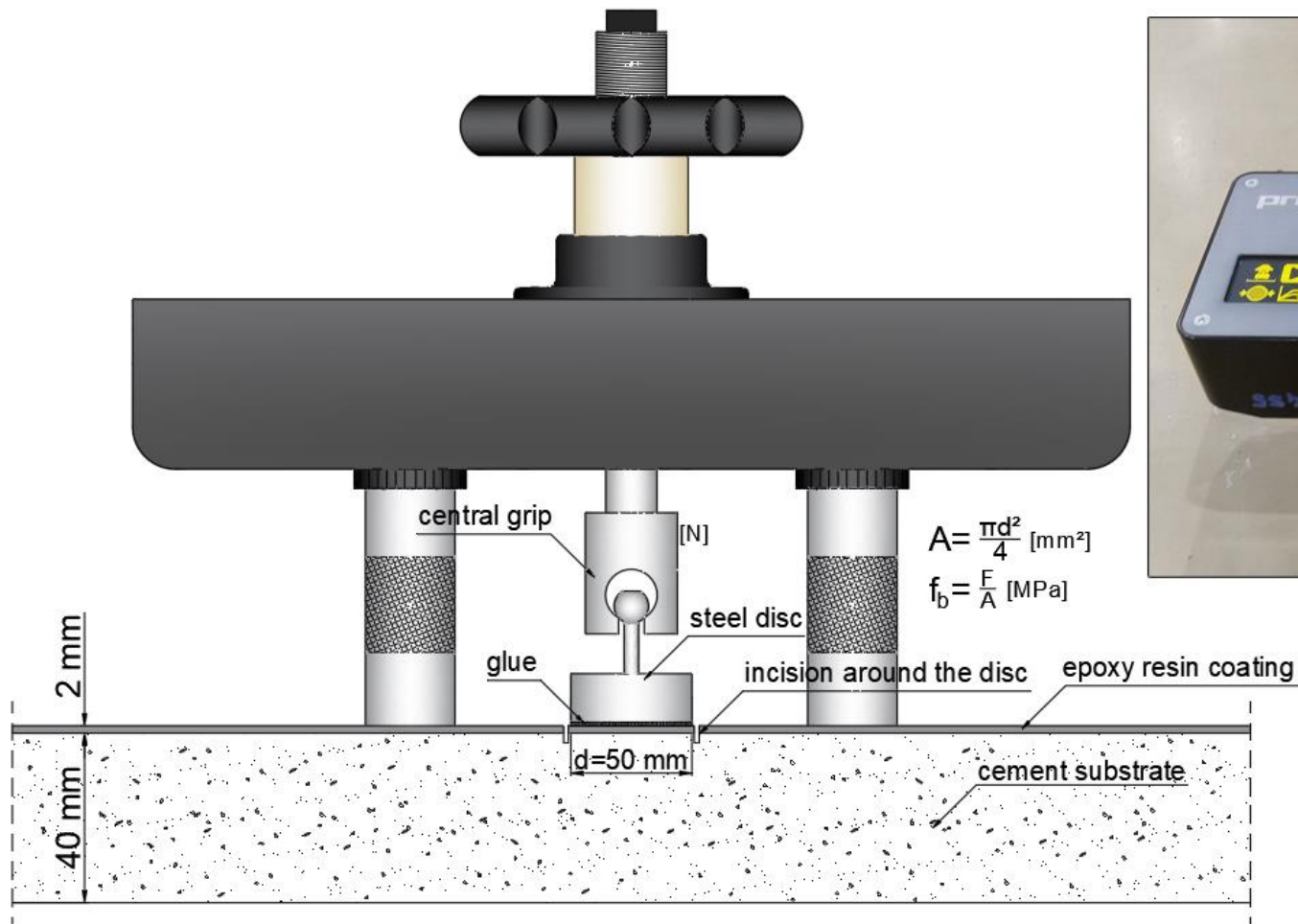



Politechnika  
Wroclawska

# Pull-off test

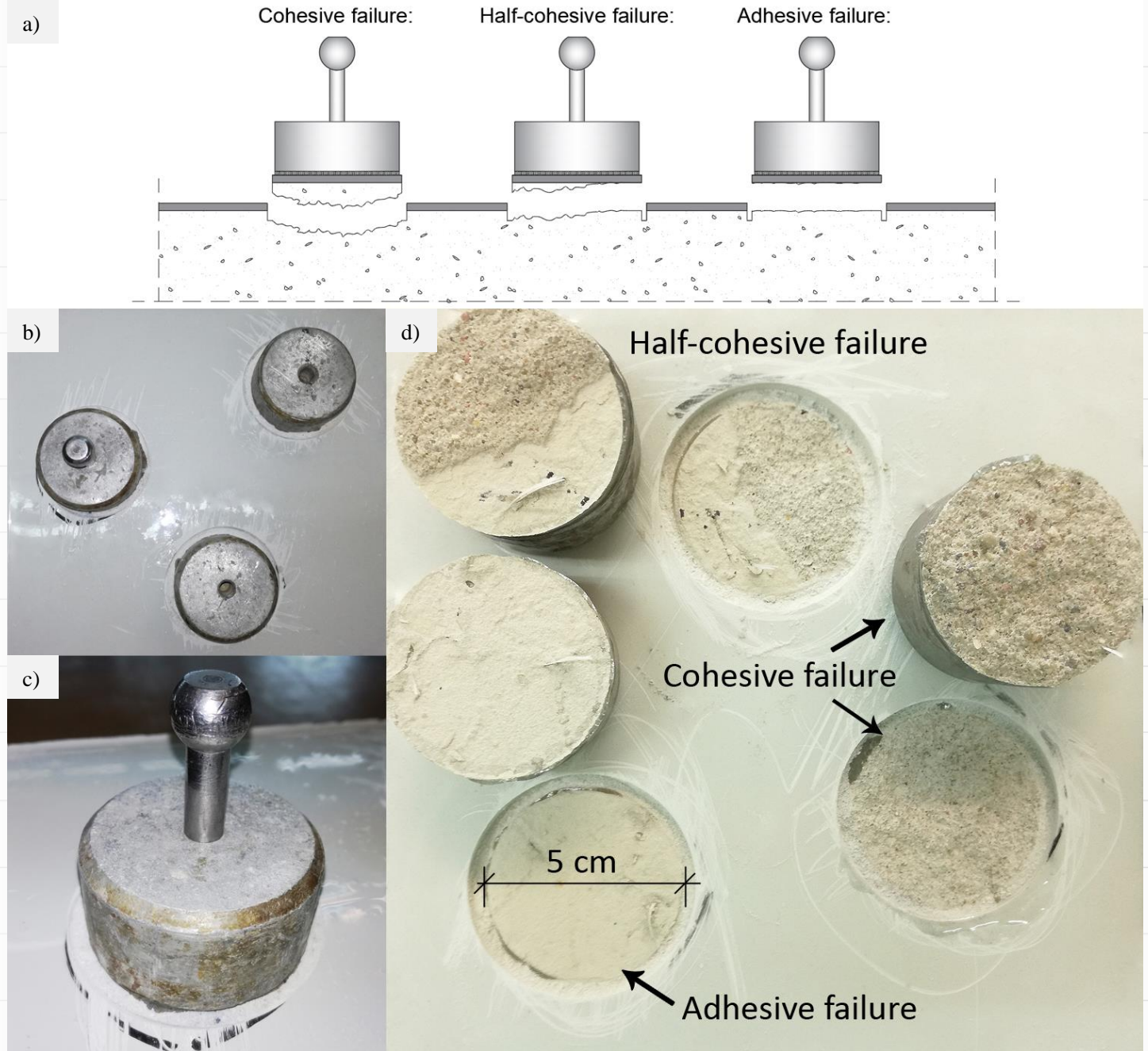

Pull-off method: b, c) view of the steel disk before detaching;  
a, d) three types of failure on raw surface.



Politechnika  
Wroclawska

# Pull-off method results

	Square designation	The content of glass powder (%)	Single results (MPa)	The average pull-off strength (MPa)	Standard deviation (MPa)	Type of failure
GR- ground surface	GS-R	0,0	2,59; 2,70; 2,83	2,71	0,12	all cohesive failure
	GS1	7,4	2,24; 2,30; 2,40	2,31	0,08	all cohesive failure
	GS2	13,8	2,25; 2,51; 2,54	2,43	0,16	all cohesive failure
	GS3	19,4	1,64; 1,82; 1,87	1,78	0,12	all cohesive failure
	GS4	24,2	2,77; 3,05; 3,38	3,07	0,31	all cohesive failure
	GS5	28,6	2,69; 2,81; 2,86	2,79	0,09	all cohesive failure
	GS6	32,4	2,12; 2,18; 2,30	2,20	0,09	all cohesive failure
	GS7	35,9	2,27; 2,33; 3,00	2,53	0,41	all cohesive failure
	GS8	39,0	2,07; 2,17; 3,08	2,44	0,56	all cohesive failure
	GS9	41,9	2,27; 2,76; 2,79	2,61	0,29	all cohesive failure
GS10	44,4	1,87; 2,13; 2,37	2,12	0,25	all cohesive failure	
RS-raw surface	RS-R	0	0,51; 0,84; 1,00	0,78	0,25	all adhesive failure
	RS1	7,4	1,41; 1,23; 1,89	1,51	0,34	2xCF; 1x half-CF
	RS2	13,8	1,06; 1,39; 2,11	1,52	0,54	all adhesive failure
	RS3	19,4	1,27; 1,36; 1,84	1,49	0,31	1xAF; 1xCF; 1x half-CF
	RS4	24,2	1,03; 1,72; 2,02	1,59	0,51	all adhesive failure
	RS5	28,6	1,79; 1,97; 2,58	2,11	0,41	all adhesive failure
	RS6	32,4	1,32; 1,69; 1,87	1,63	0,28	2xAF; 1x half-CF
	RS7	35,9	1,69; 2,05; 2,19	1,98	0,26	all adhesive failure
	RS8	39	0,48; 0,83; 1,70	1,00	0,63	all adhesive failure
	RS9	41,9	1,55; 1,99; 2,03	1,86	0,27	all cohesive failure
RS10	44,4	0,85; 1,06; 1,30	1,07	0,23	all cohesive failure	

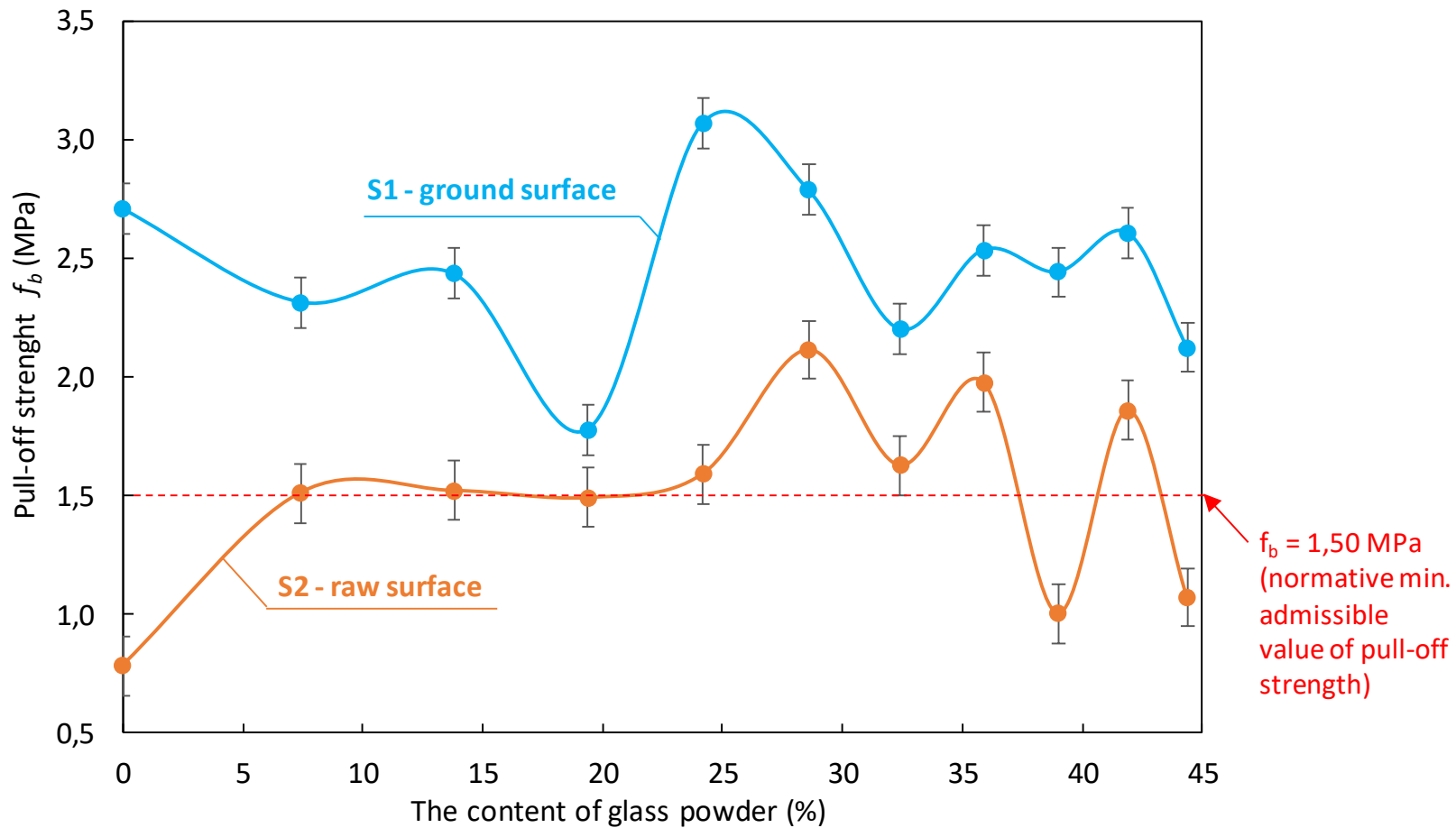

Graph of the dependence of peel strength on the content of glass powder.





# SEM results

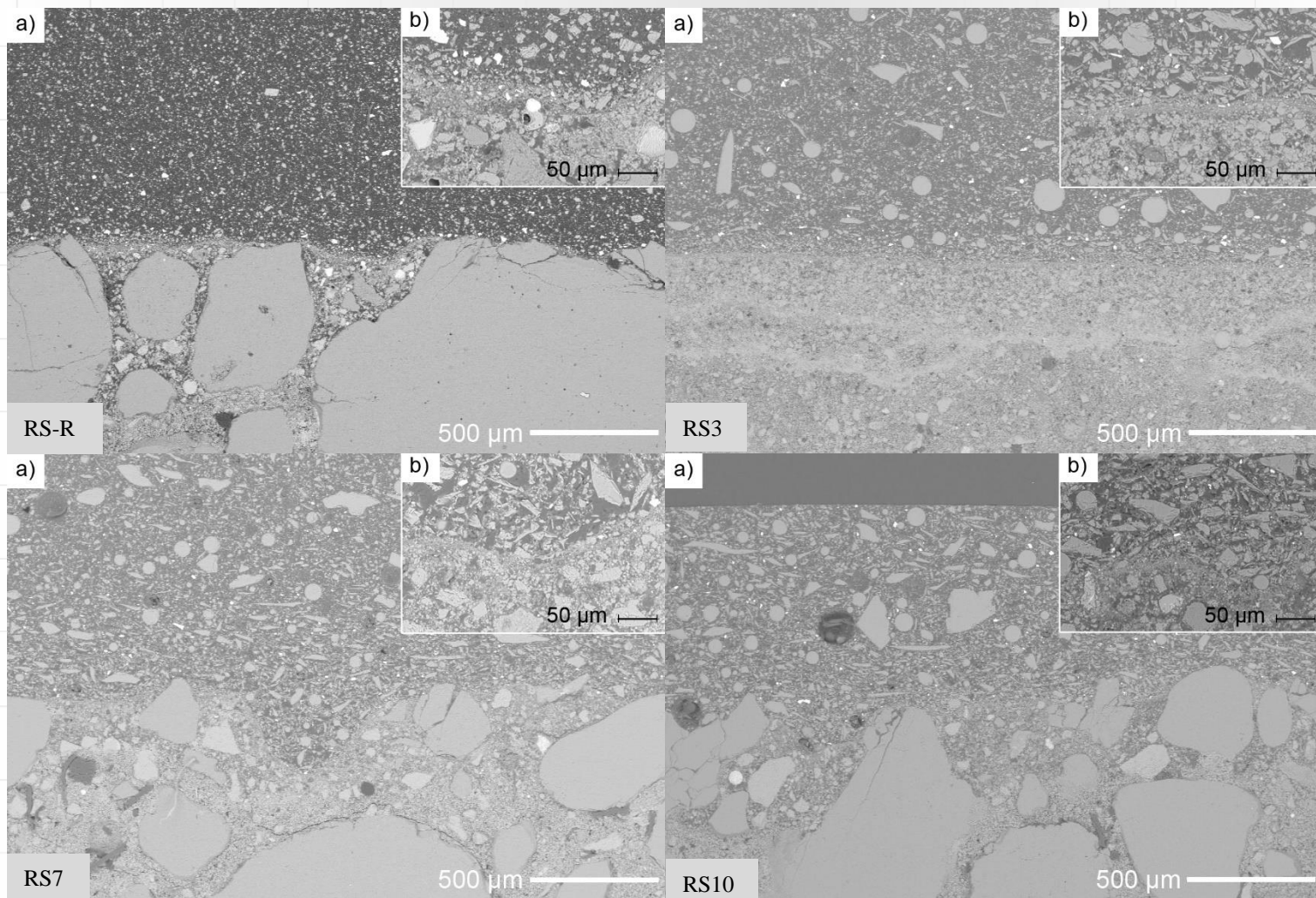

View from SEM for sample RS-R (0%), RS3 (19,4 %), RS7 (35,9%)  
and RS10 (44,4%) at a larger scale: a) x50, b) x400

# Chemical analysis

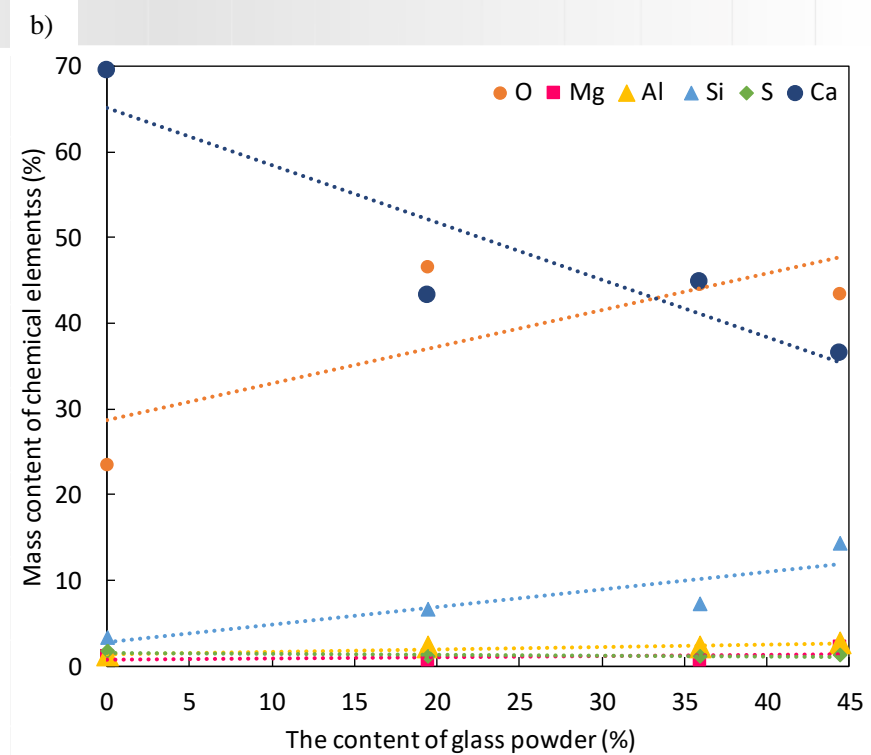
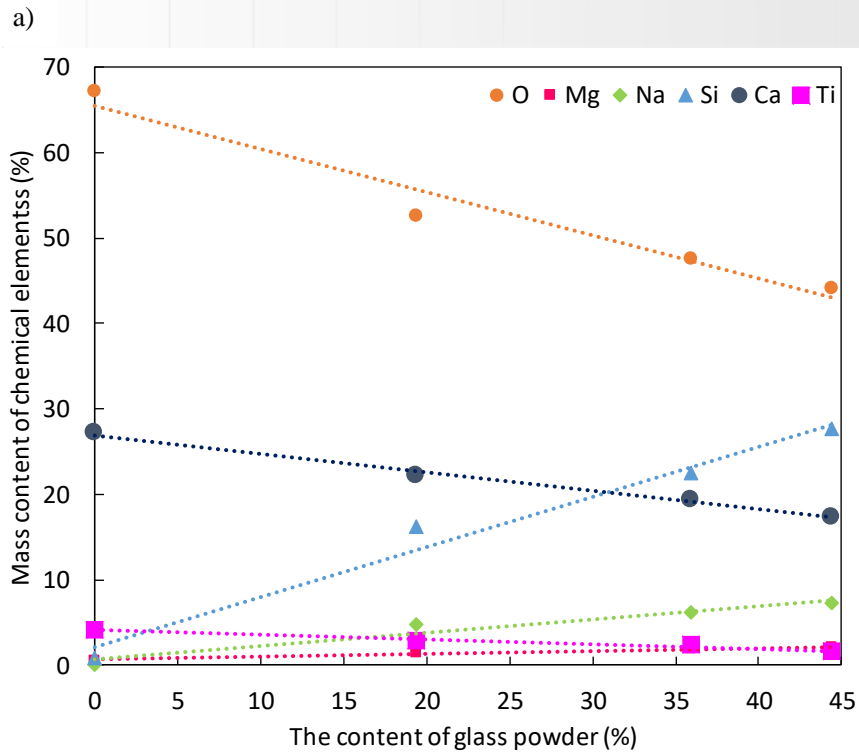

The mass content of elements a) in the coating; b) in the substrate





Politechnika  
Wroclawska

# Chemical analysis

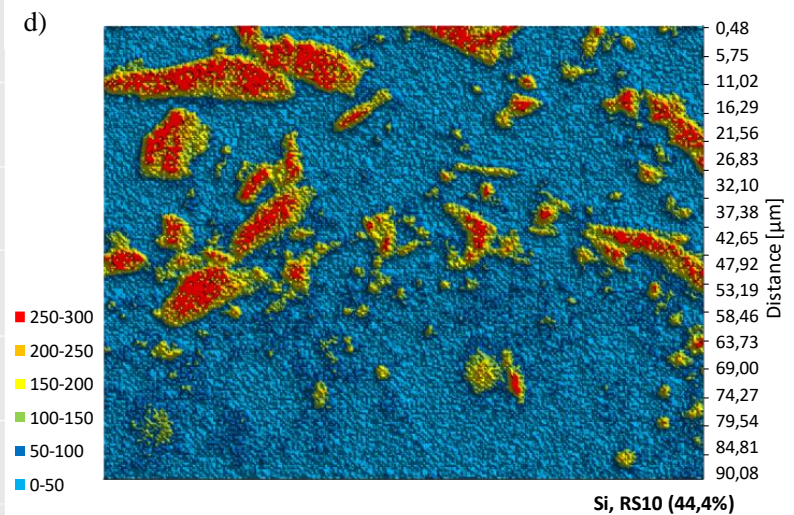
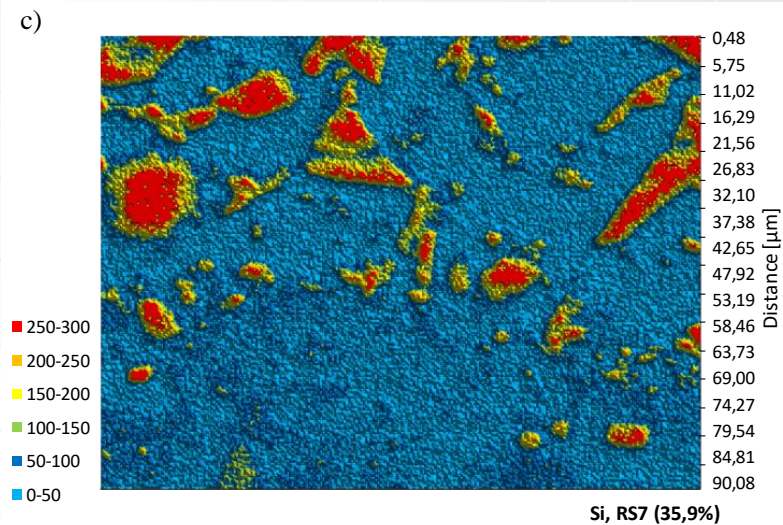
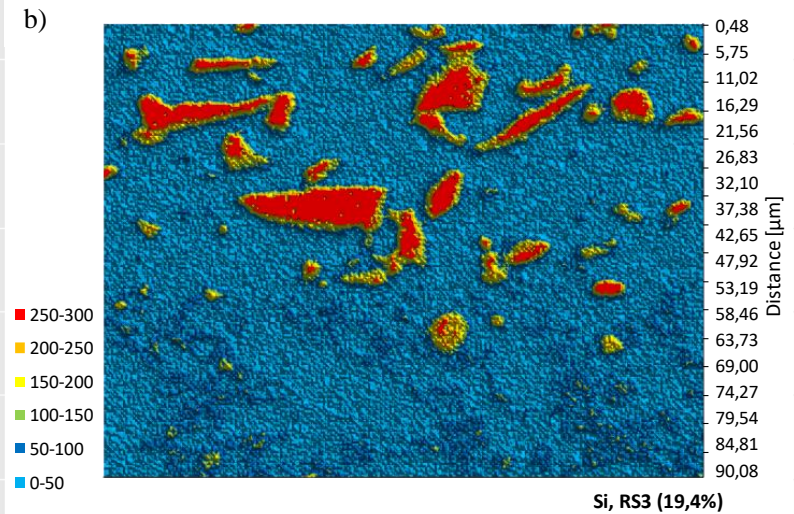
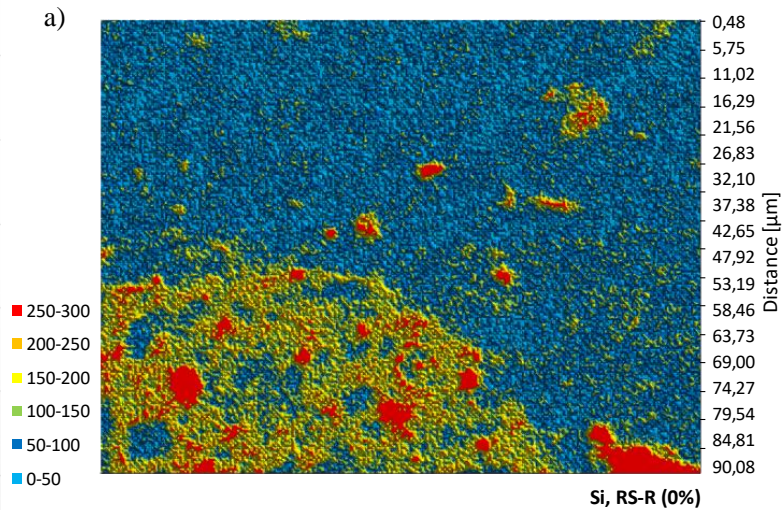

Images of Si intensity for squares a) RS-R (0%), b) RS3 (19,4%),  
c) RS7 (35,9%), d) RS10 (44,4%)





Politechnika  
Wroclawska

# Chemical analysis

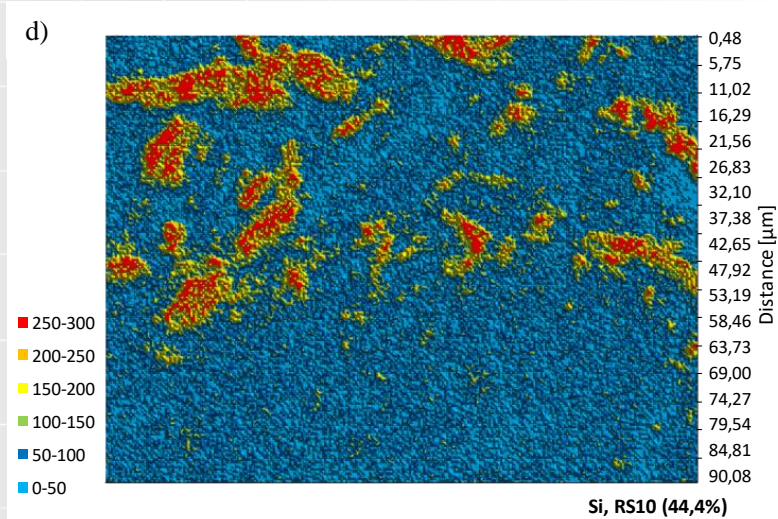
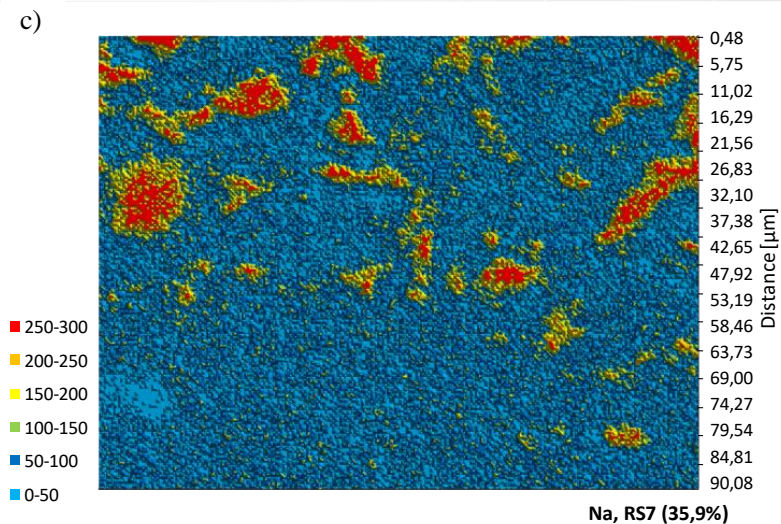
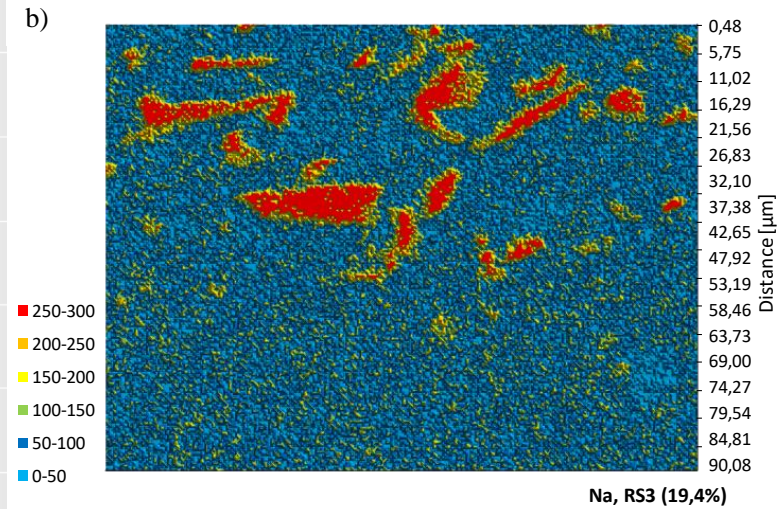
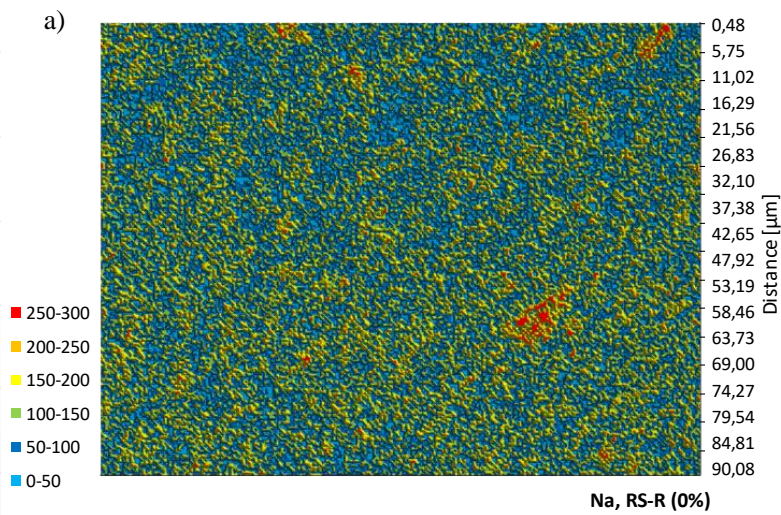

Images of Na intensity for squares a) RS-R (0%), b) RS3 (19,4%),  
c) RS7 (35,9%), d) RS10 (44,4%)

# Chemical analysis

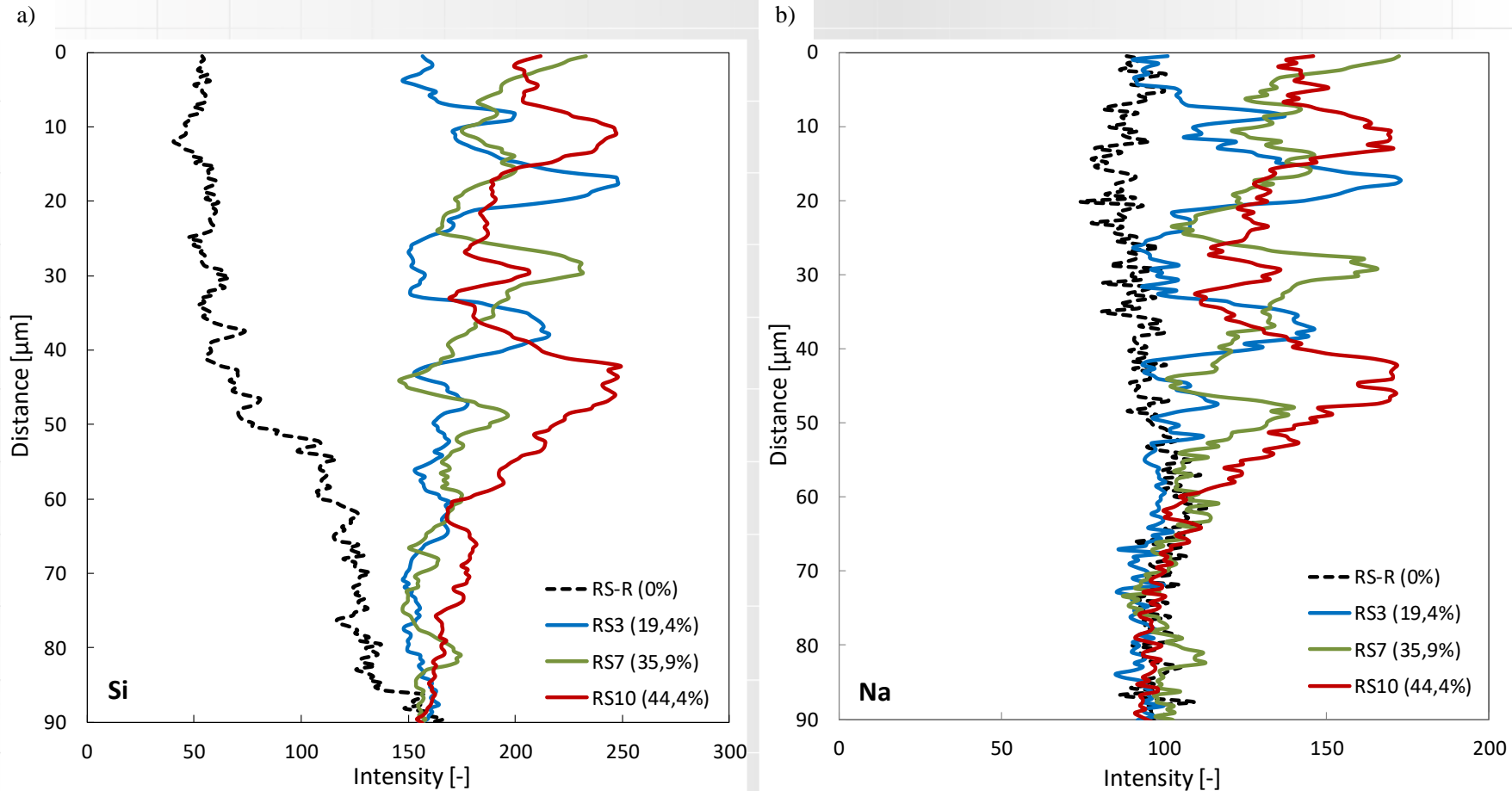

Graph of intensity of occurrence of height: a) Si, b) Na

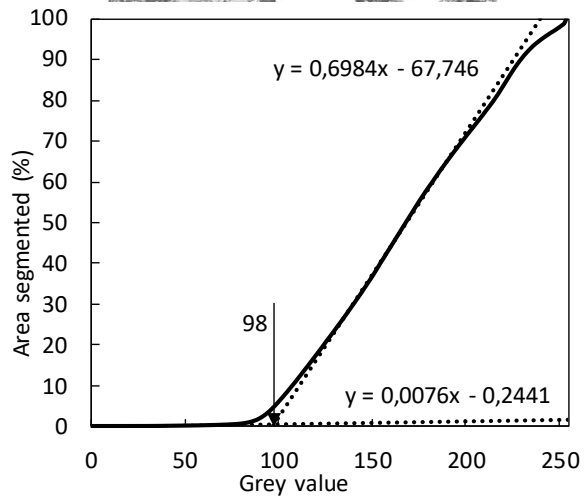
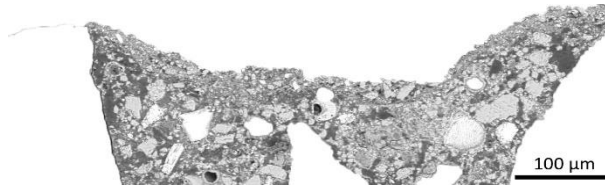

a) RS-R (0%)

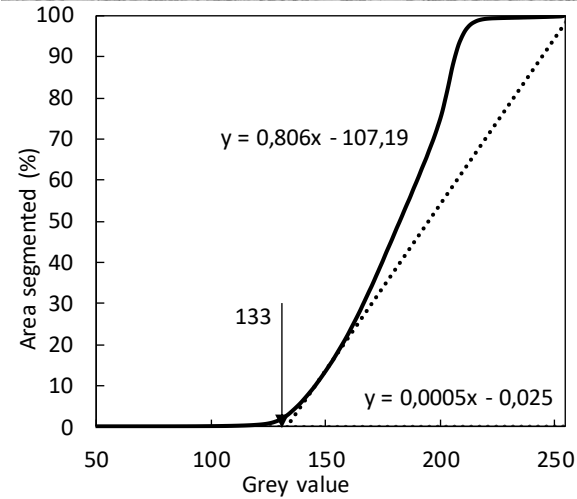
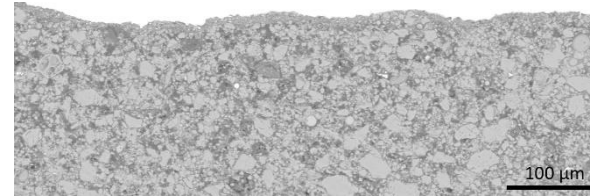

b) RS3 (19,4%)

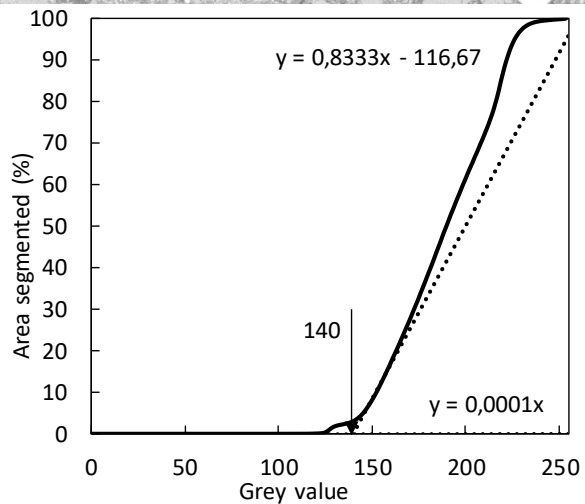

c) RS7 (35,9%)

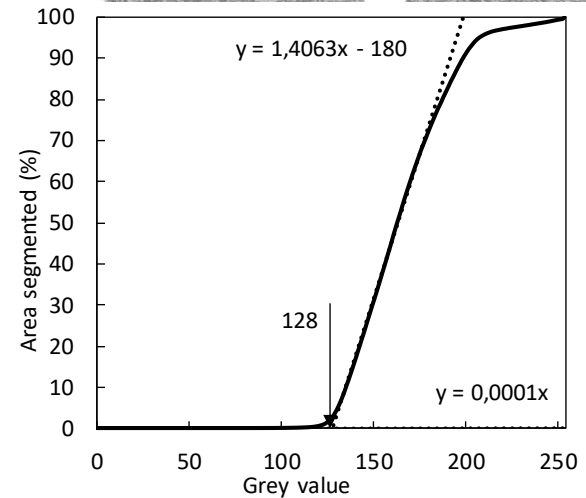
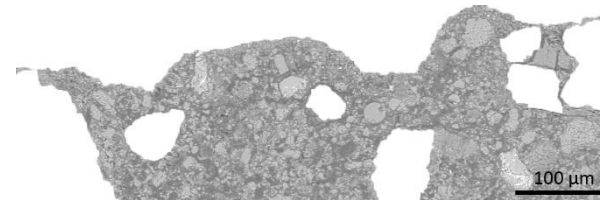

d) RS10 (44,4%)

a) RS-R (0%)

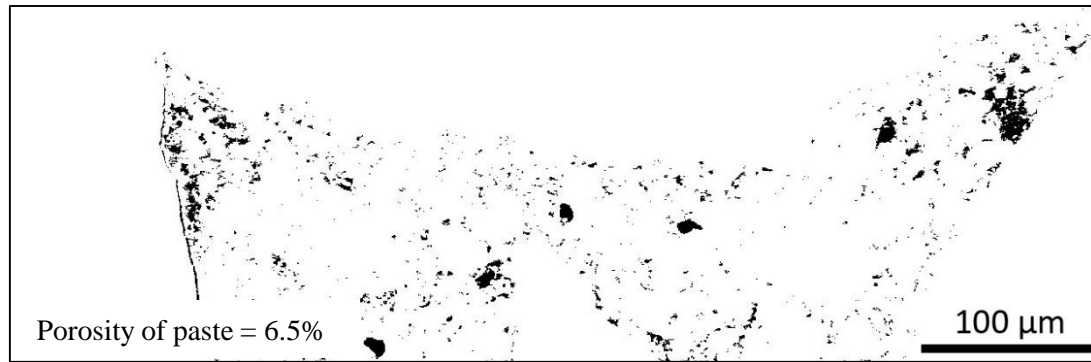

b) RS3 (19,4%)

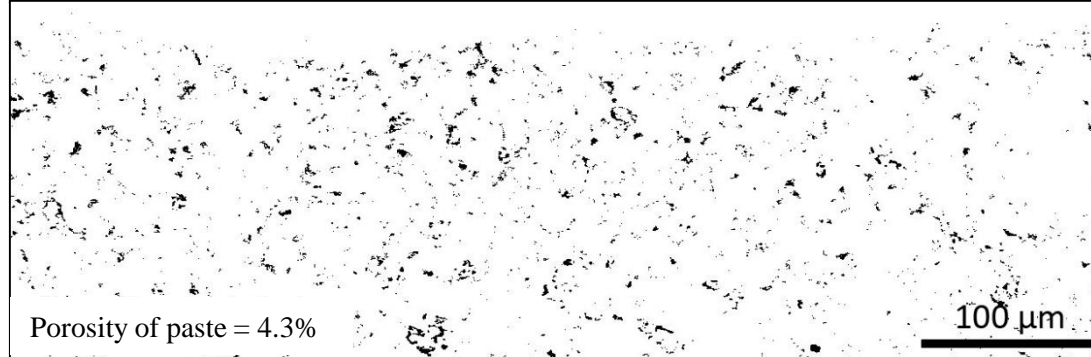

c) RS7 (35,9%)



d) RS10 (44,4%)

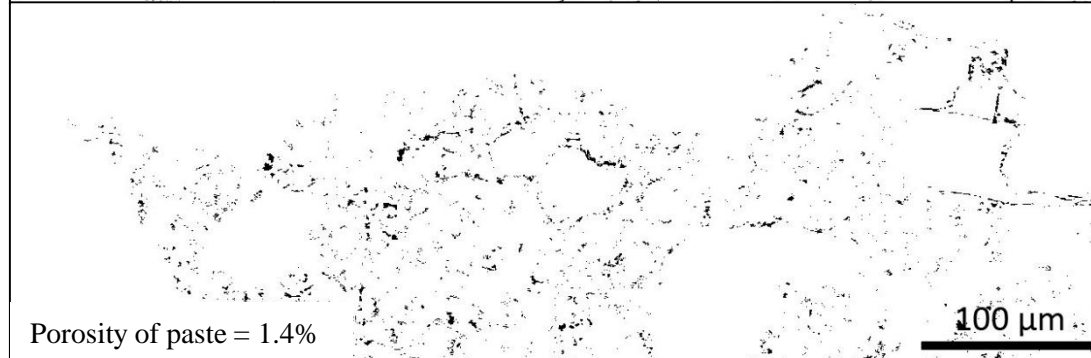

# Graphs of porosity of sample height

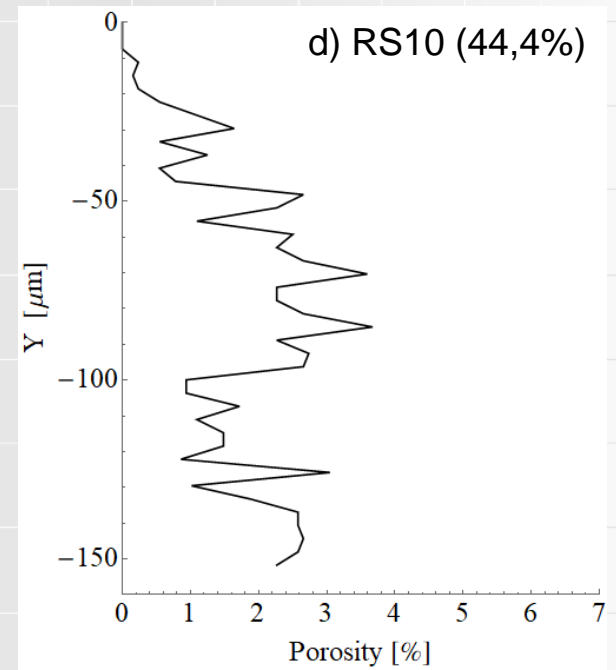
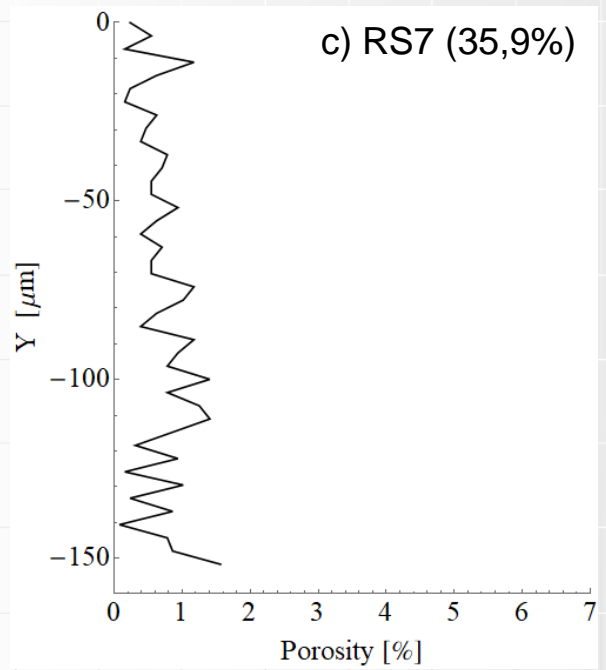
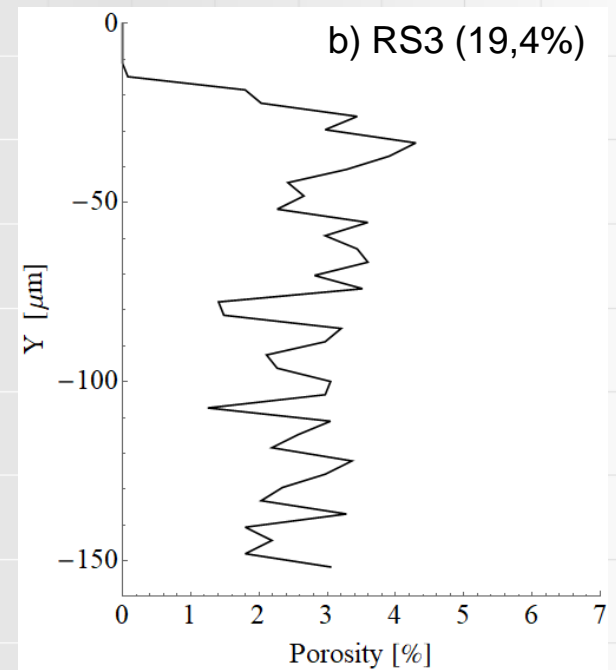
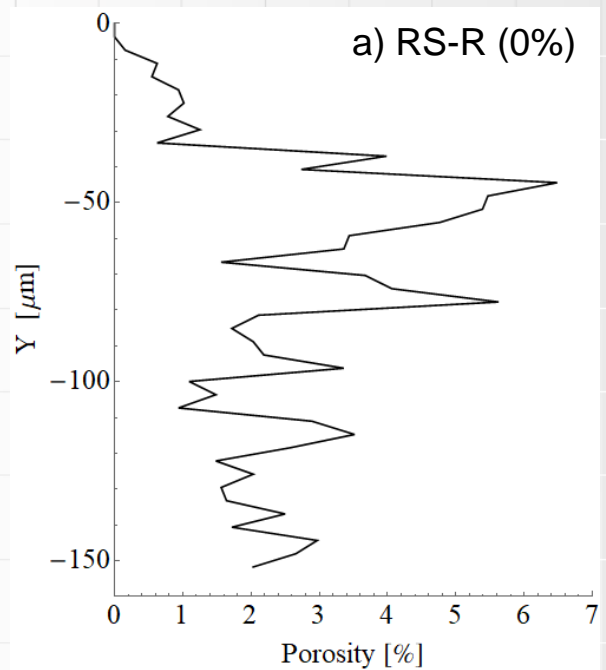





# Possible applications of technology

**Industrial Flooring Segment: Percent Unit Shipment by End-use Application, Europe, 2015**

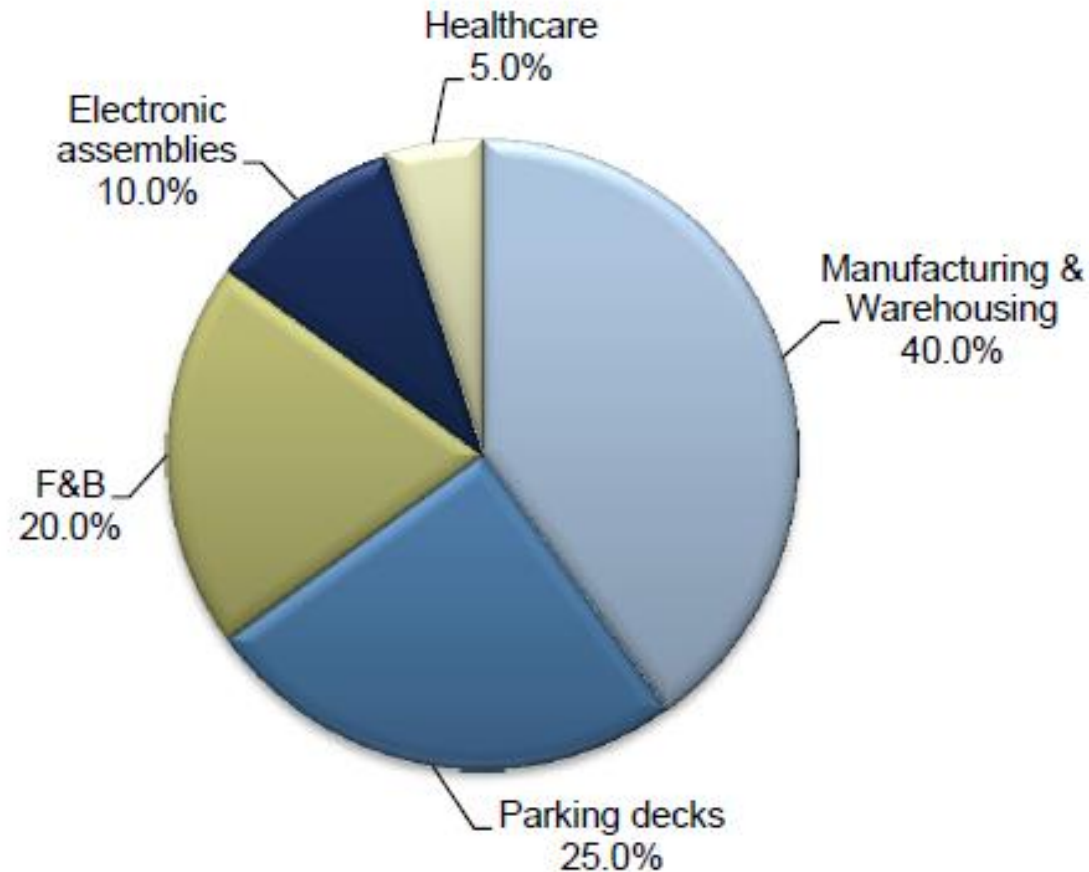

# Tasks to be performed for the next class

1. Describe main possibilities and phenomena of adhesive bonding between selected 3 materials (or combination of 3 processes) used your research,
2. Search for scientific articles in Scopus related to the adhesive bonding (or combination of 3 processes) of your 3 selected materials (or processes),
3. Describe the content of 3 most cited articles related to adhesive bonding (or combinations) based on your Scopus search.